

PowerStation XP Series User Guide



November 2007

*Parker Electromechanical
50 W. TechneCenter Drive, Milford, Ohio 45150*

Part #: A3-06720-101



Copyright and Trademark Notice

Copyright © 2007 by Parker Electromechanical. All rights reserved. No part of this publication may be reproduced, transmitted, transcribed, stored in a retrieval system, in any form or by any means, mechanical, photocopying, recording or otherwise, without the prior written consent of Parker Electromechanical.

While every precaution has been taken in the preparation of this manual, Parker Electromechanical and the author assume no responsibility for errors or omissions. Neither is any liability assumed for damages resulting from the use of the information contained herein. All product and company names are trademarks of their respective companies and licenses.

The following products are copyright their respective owners: Microsoft, Microsoft Windows, Intel, SanDisk, and SanDisk ImageMate.

Product Warranty Information

Parker Electromechanical provides top quality products through rigid testing and the highest quality control standards. However, should a problem occur with your hardware or with the software protection key, Parker's standard product warranty covers these items for 24 months from the date of shipment from Parker. Exceptions appear below:

- PowerStation backlight bulbs have a 90-day warranty.
- Third-party products, such as bus cards, carry the manufacturer's specified warranty.
- For all displays, image retention (burn-in) is not covered by warranty.
- Software revisions that occur within 60 days after purchase are available under warranty upon request. Please review the Interact License Agreement for additional software warranty information.

Should you have any questions about your application or need technical assistance, please call Parker Electromechanical's Product Technical Support department at 513-248-1714, 8:00 a.m. to 5:00 p.m., Eastern Time. You may call this same number after hours for emergency assistance. See *Customer Support Services* on page 1-4 for more information about support products and services.

Table of Contents

1 Introduction	1-1
Using this Manual	1-1
Software Components	1-2
Downloading Applications and Projects	1-2
Documentation Library	1-3
Documentation Standards	1-3
Text Conventions	1-3
ISO Symbols	1-4
Customer Support Services	1-4
Product Technical Support	1-5
Technical Training	1-5
Getting Started	1-6
2 Installing the PowerStation	2-1
Selecting a Location	2-1
Underwriters Laboratories Approval	2-1
Environmental Guidelines	2-2
Touchscreen Considerations	2-2
Electrical Guidelines	2-2
Field Terminal Wiring Requirements	2-2
Temperature and Humidity Guidelines	2-2
Enclosure Guidelines	2-4
Radiated Emissions Guidelines	2-4
Class I, Division 2 Guidelines	2-5
Preparing for Installation	2-6
Creating the Cutout	2-6
Installing the XP PowerStation	2-7
Mounting a PowerStation With a 6" Display	2-7
Mounting a PowerStation With an 8" Display	2-9
Mounting a PowerStation With a 10" Display	2-11
Mounting a PowerStation With a 15" Display	2-13
Installing an Optional AC Power Supply	2-15
Preparing a Location for the AC Power Supply	2-15
Prepare the Power Supply Mounting Surface	2-15
Mounting the AC Power Supply	2-15
Connecting the Power Supply to the Workstation	2-16
3 Starting Your PowerStation	3-1
PowerStation Connectors	3-2
Serial Ports	3-2
Settings and Pinouts for COM1	3-3
Settings and Pinouts for COM2 on the XPR00 & XPx06	3-3

Settings and Pinouts for COM2 on the XPx08/XPx10/XPx15	3-5
RS-485 Directional Control on a 6" PowerStation	3-7
RS-485 Directional Control on 8", 10", and 15" PowerStations	3-7
Transferring Files from a PC to the XP PowerStation	3-7
Keyboard and Mouse Ports	3-8
Ethernet Port	3-8
CompactFlash	3-9
Starting the PowerStation	3-10
Using the CompactFlash Card	3-11
Writing to the CompactFlash Card	3-11
Using the BIOS Utility	3-12
Using the BIOS Utility with an XPx06 Unit	3-12
Entering Setup	3-12
Using the BIOS Utility with an XPx8, XPx10, or XPx15 Unit	3-14
Navigating the BIOS Utility	3-14
Entering Setup	3-14
Resetting Disk Boot Priority	3-16
Load Optimized Defaults	3-17
4 Maintaining the PowerStation	4-1
Maintaining the Touchscreen	4-1
Cleaning the Touchscreen	4-1
Calibrating the Touchscreen	4-2
Calibrating the Touchscreen on a Windows CE PowerStation with Xpress	4-2
Calibrating the Touchscreen on a Windows CE PowerStation without Xpress	4-2
Calibrating the Touchscreen on a Windows XP PowerStation	4-3
Replacing the CompactFlash	4-4
Performing Internal Maintenance	4-5
Electrostatic Discharge (ESD) Precautions	4-5
Removing the PowerStation from an Enclosure	4-6
Opening the PowerStation	4-6
For 6" XP PowerStations Only	4-7
Closing the PowerStation	4-8
Replacing the Fuse	4-9
Replacing the Fuse on an XPx06 PowerStation	4-9
Replacing the Fuse on an XPx08, XPx10, or XPx15 PowerStation	4-10
Optional Components	4-11
AC Power Supply	4-11
Accessing the PowerStation Utilities	4-12
Reinstalling Microsoft Windows on an XPC PowerStation	4-12
Recovery Software on systems containing hard drives	4-12
Ordering Replacement Components	4-12
A PowerStation Specifications	A-1
Physical Specifications	A-2
Display Specifications	A-3
Environmental Specifications	A-4

Electrical Specifications	A-5
Testing Specifications	A-6
Faceplate Chemical Resistance	A-7

INTRODUCTION

Thank you for purchasing an XP PowerStation. The XP PowerStation is a rugged, compact PC that is designed to be used as an industrial operator interface.

The XP PowerStation has an all-in-one PC board with Serial, Ethernet, Audio Output, and USB ports. The XP PowerStation's PC architecture allows you to run Parker's Interact Xpress software.

Please take time to review this manual and the other documentation included with the XP PowerStation before operating the unit.

Using this Manual

This manual is designed to help you set up and use your XP PowerStation. The manual lists the PowerStation's specifications and describes its replacement and optional components. It also explains how to install the unit and how to maintain the unit in good condition.

This manual is divided into the following chapters:

Chapter 1 — Introduction: Presents an overview of this manual, the other documentation and software provided with the XP PowerStation, and the steps necessary to get your PowerStation up and running. This chapter also describes Parker's customer support services.

Chapter 2 — Installing the PowerStation: Explains how to select an installation location, prepare for installation, and finally install the XP PowerStation.

Chapter 3 — Starting Your PowerStation: Describes the ports available to connect the PowerStation to other devices and to a power source. And then explains how to start up the PowerStation.

Chapter 4 — Maintaining the PowerStation: Explains how to maintain the XP PowerStation, including the touchscreen, replacing the CompactFlash, performing internal maintenance, and accessing the PowerStation utilities.

Appendix A — PowerStation Specifications: Describes the XP PowerStation's specifications.

Software Components

There are two types of PowerStations in this series: XPR and XPC.

- The XPR comes with a Windows CE 5.0 operating system and is bundled with Parker's Interact Xpress software.
- The XPC comes with a Windows CE 5.0 or Windows XP operating system and does not include the Interact Xpress software.

Each PowerStation is shipped with a utilities CD containing drivers and backup copies of available software.

Downloading Applications and Projects on an XPR PowerStation

The XP PowerStation is a runtime-only system, which means that you must develop your applications and projects on a development PC and download the application to the PowerStation.

Note Throughout this manual, all references to "development PC" or "development system" refer to the laptop or computer you use to develop applications.

See the documentation that came with your development software, such as Interact Xpress, for information about how to develop your applications or projects and download them to the PowerStation.

Documentation Library

The documentation set for this monitor contains:

Release Notes - Release notes are provided whenever there is important information about the PowerStation that does not appear in this manual. Be sure to read any available release notes before installing or operating the unit.

PowerStation XP Series User Guide - This document contains all the information you need to configure, install and use the PowerStation.

You can download CTC-Parker product documentation from our web site at www.ctcusa.com. Click on the *Support* link then select *Product Manuals* to find the appropriate manual.



Documentation Standards

As you read this manual, notice that it uses the following documentation standards:

Text Conventions

Style	Type of Text
Bold	Names of buttons, tabs, menus, menu items, commands, files, keyboard keys, dialog boxes and other important terms.
<i>Italic</i>	Titles of User Guides, chapters, or sections and cross-references.
Courier font	Text to be entered from a keyboard.
+	Indicates two or more keyboard keys that must be pressed simultaneously. For example, Ctrl+Alt+Delete .
Note	Alternative approaches or issues you should be aware of while using a particular function.
Important	Information that will save time and minimize problems.
Warning	Information that will prevent equipment damage or personal injury.

ISO Symbols

Symbol	Meaning
	This symbol is the International Standards Organization (ISO) symbol for Caution (ISO 3864 No. B.3.1). This symbol denotes information that could affect operation of the monitor if the information is not properly followed.
	This symbol is the ISO symbol for Caution - risk of electrical shock (ISO 3864 No. B.3.6). This symbol denotes information that could cause personal injury from electrical shock or damage to equipment if the information is not properly followed.

Customer Support Services

Parker welcomes your thoughts and suggestions on our products and services. You can contact Parker Electromechanical by telephone, email or fax. You can also visit us on the World Wide Web to learn about the latest hardware, software, and customer support services.

Customer Support	
Main Telephone	513-831-2340
Technical Support	513-248-1714
Fax	513-831-5042
E-mail	Sales: emn_sales_ctc@parker.com
	Support: emn_support_ctc@parker.com
	Training: emn_training_ctc@parker.com
World Wide Web	http://ctcusa.com or http://parkermotion.com

Parker recognizes that every customer and every application has different support needs, as a result Parker offers a variety of support services designed to meet these needs. Parker offers two types of customer support services:

- Product Technical Support
- Technical Training

Product Technical Support

The Product Technical Support department welcomes any questions that might arise as you develop or run your applications. We offer complimentary support for all customers, including end users, original equipment manufacturers (OEM), system integrators or distributors.

If you have a question about the PowerStation, be sure to complete the following steps:

- Check any release notes that shipped with the unit. These notes provide important information about the PowerStation.
- Consult the documentation and other printed materials included with the PowerStation.
- Review *Chapter 4, Maintaining the PowerStation*.
- Visit the CTC-Parker Web site and register for the support forum. You can find the support forum by clicking on the *Support* tab from the Web site's home page: <http://www.ctcusa.com>.

If you cannot find a solution using one of the above sources, contact our Product Technical Support department at 513.248.1714, 8:00am to 5:00pm Eastern Standard time.

Technical Training

CTC-Parker offers training on all of our products, either at Parker in our state-of-the-art training facility, or at your site.

You can contact the Training Coordinator by telephone or e-mail:

- Telephone: 1-800-233-3329
- E-mail Parker Training: emn_training_ctc@parker.com

You can view a current training schedule on our web site at www.ctcusa.com.

Getting Started

Now that you have opened the PowerStation, you are ready to unpack the unit, install it in a permanent location, and develop an application for it. Follow the steps below to get started.

- 1 Unpack the PowerStation and verify that you have received all of the components you ordered.
- 2 Install the PowerStation in a permanent location. See Chapter 2, *Installing the PowerStation*, for complete installation instructions.
- 3 Review the available connectors for the PowerStation, see *The PowerStation Connectors* on page 3-2, for details.
- 4 Start up your PowerStation. See *Starting the PowerStation* on page 3-10, for more information.
- 5 Develop your application and download it to the PowerStation.

INSTALLING THE POWERSTATION

Once you have unpacked the PowerStation and verified that you have received all of the components you ordered, you are ready to install the PowerStation in a permanent location.

This chapter covers the following topics:

- Selecting a Location
- Preparing for Installation
- Installing the XP PowerStation

Selecting a Location

The first step when installing the XP PowerStation is to select an appropriate location for the unit. This is the most important aspect of the installation process because the location you select can affect the PowerStation's performance, ease-of-use, and life-expectancy. This section provides some guidelines that you should follow when selecting a location for the PowerStation.

Underwriters Laboratories Approval

In order to obtain Underwriters Laboratories (UL) approval for your PowerStation installation, the installation must meet the following criteria:

- 1 The PowerStation must be mounted in a standard industrial enclosure that provides fire protection.
- 2 The PowerStation products have been approved for NEMA Type 4/4X (indoor) and Type 12 ratings when mounted in a customer provided listed Type 4/4X or Type 12 enclosure.

Environmental Guidelines

The environment is the area where the XP PowerStation will be located. In general, you should select a place that limits the unit's exposure to adverse conditions such as dust, oil, moisture, and corrosive vapors.

Touchscreen Considerations

The XP PowerStation's touchscreen is designed to meet the NEMA 4/4X and Type 12 rating. However, it is only rated NEMA 4 when properly mounted in a NEMA 4/4X or Type 12 enclosure.

The XP PowerStation's touchscreen is resistant to a variety of chemicals. See *Faceplate Chemical Resistance on page A-7* for a list of these chemicals. Make sure that the touchscreen is not exposed to chemicals other than those listed in *Faceplate Chemical Resistance on page A-7*.

Electrical Guidelines

To minimize unwanted electrical interference, select a location away from machinery that produces intense electrical noise. If you cannot do this, isolate input power to the unit and separate all data communication cables used with the unit from AC power lines.

All serial communication cables should be 100% shielded with the shield tied to chassis ground at one end of the cable only.

See *Electrical Specifications on page A-5* for a list of the XP PowerStation's electrical specifications. Make sure that your power source is compatible with the PowerStation before starting the unit.

Field Terminal Wiring Requirements

In order to comply with UL 508 and 1604 requirements, use copper wire with 60C or 60/75C insulation and a tightening torque of 7.0 lb/in. (0.79 N·m) when connecting field terminal wiring to the PowerStation.

Temperature and Humidity Guidelines

You can safely operate the XP PowerStation within the temperature range specified in *Environmental Specifications on page A-4*. However, if you are using a protective enclosure, remember that the temperature within an enclosure is generally higher than the external temperature. Read these guidelines to fully understand temperature implications.

The XP PowerStation can dissipate approximately 10 watts on an 6" unit with a CF drive. The 8", 10", and 15" units can dissipate approximately 20 watts.

Heat builds up rapidly in enclosed environments, compromising the performance and life span of electrical equipment. If the PowerStation is operating inside an enclosure at temperature levels above its rated ambient temperature, you must cool the enclosure.

XP PowerStation's have been tested for use in 50°C ambient, still air locations. This means that when installed, the ambient air surrounding the backside of the PowerStation is not expected to exceed 50°C. An example of this type of installation would be a PowerStation mounted in a small, sealed industrial enclosure.

The most commonly overlooked aspect of this type of installation is that heat generated by the device becomes trapped inside the enclosure and increases the ambient temperature surrounding the PowerStation. This increase in temperature can sometimes exceed 15°C or more.

Although the thermal dynamics are not always linear, a temperature rise of 15°C would imply that the environment outside the sealed enclosure could not exceed 35°C (95°F), or the PowerStation would surpass its maximum operating temperature.

Do not mount a PowerStation into a sealed enclosure and mistakenly think that due to the 50°C rating of the product, the sealed enclosure can operate in a 50°C ambient environment without considering the affects of the internal heat build up.

Since elevated operating temperatures can have negative affect on the life of electronics, it is wise to consider the internal thermal rise. Passive venting for thermal convection, internal air circulation fans, filtered exhaust fans with filtered inlets, air conditioners, and other products are available in the market to assist in reducing the heat build up in the industrial enclosure.

There are many attractive NEMA Type 12, dust-tight fan/filter assemblies available today in which the filter can be inexpensively replaced or cleaned as part of a periodic maintenance schedule. Or in some cases, simply increasing the size of the enclosure, and thus the outside surface area for example, can have a significant, positive affect on the installation's thermal response.

Points to consider when performing a site review are:

- 1 What is the expected maximum outside ambient temperature that the industrial enclosure will experience?
- 2 Are there additional heat-generating components inside the enclosure?
- 3 What is the size of the enclosure? Larger enclosures dissipate more thermal energy than smaller ones.
- 4 In what kind of environment will the enclosure be installed - clean, water-tight, dust-tight? Can the enclosure be convection cooled or is active cooling required?

In summary, it is a wise investment to thermally plan the installation by anticipating, and eliminating, the heat build up inside a sealed enclosure. Not only will this extend the life of the electronics, but it will also reduce costly equipment downtime.

Enclosure Guidelines

Select an enclosure that is large enough to allow free airflow in and around the unit. You should allow a minimum of 2 inches between the enclosure and the top, bottom, and sides of the XP PowerStation to allow access to the cabling and CompactFlash.

Also, make sure that the surface of the enclosure on which the XP PowerStation is mounted is flat and free of raised or depressed areas.

Radiated Emissions Guidelines

This PowerStation has been tested to comply with international electromagnetic and emission standards. To reduce radiated emissions, ensure that there is a good earth connection to the PowerStation, which can be accomplished by utilizing the grounding stud located on the rear chassis of the product. This connection must be made with the shortest possible, heavy gage wire or braided cable. Low-resistance (<0.5 ohms) continuity should be verified with an ohmmeter for proper grounding. In addition, all communication cables should be shielded and grounded on only one end.

Class I, Division 2 Guidelines

If you purchased a Class I, Division 2-compliant PowerStation, it is suitable for use in Groups A, B, C, and D hazardous locations. You must follow these guidelines in order to maintain a safe operating environment.

- When performing field wiring, always use copper wire with 60C or 60/75C insulation and a tightening torque of 7.0lbs/in (0.79 N-m).
- Substitution of components can impair suitability for Class I, Division 2.
- The XP PowerStation is intended to use a branch circuit protection rated 20 Amps *or less*.



WARNING!

Explosion Hazard!

- Do not connect or disconnect cables or equipment unless the power has been switched off, or the area is known to be non-hazardous. USB or PS/2 keyboard and mouse ports are for system setup and diagnostics *only* and are not intended for permanent connection.
- Class I, Division 2 approval requires nonincendive field wiring for Class I, Groups A, B, C, and D hazardous locations only. With a temperature code of T5.
- Class I, Division 2 requires a power switch restraint in hazardous environments.

Preparing for Installation

Once you select a location for the XP PowerStation, you will need to create a cutout for the unit.

If you plan to operate the XP PowerStation using AC power, and you purchased Parker's optional AC Power Supply, you will need to prepare a location for the Power Supply also.

Procedures for creating the cutout and preparing a location for the AC Power Supply are described below. If you already have an appropriate cutout and are using DC power, continue with See *Installing the XP PowerStation* on page 2-7.

Creating the Cutout

Be sure to follow the cutout diagrams in the dimensional drawings precisely. This ensures that the PowerStation is properly sealed in its enclosure. You can find the dimensional drawings on the XP PowerStation CD shipped with your unit.

- 1 Measure the cutout dimensions as shown in the table below.
- 2 Attach the template securely to the mounting surface.
- 3 Cut out the shaded area on the template referred to as the *Panel Cutout Area*. To ensure the flatness of the mounting surface, when punching out the mounting hole, maintain proper surface flatness and edge quality.

The cutout dimensions for the XP PowerStation are shown in the following table:

XP Model	Cutout Height	Cutout Width
XPR00	n/a	n/a
XPx06VT	4.50"	6.20"
XPx08VT	6.08"	8.67"
XPx10VT	9.95"	12.6"
XPx10ST	9.95"	12.6"
XPx15XT	12.40"	15.90"

- 4 Debur the edges of the cutout area, removing dirt and debris that might come in contact with the unit.
- 5 More information is available on the CD that comes with the XP PowerStation. Be sure to refer to the dimensional drawings found on the CD when creating your cutout.

Installing the XP PowerStation

Once you have prepared the location for your PowerStation, you are ready to install the unit. To do so, you need to mount the PowerStation to your enclosure using screws and metal clamps in what is called a **bracket assembly**.

The bracket assembly contains a mounting clamp with “feet”, a screw, and for 15” units, a nut as shown in Figure 2-1.

Figure 2-1: Mounting Clamp

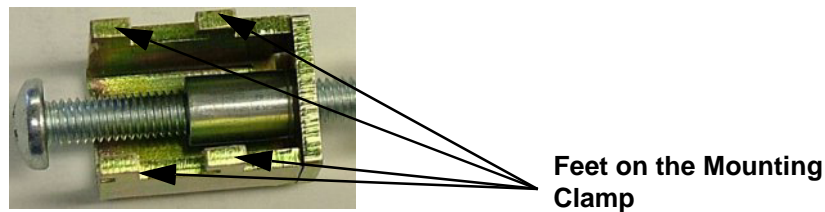

The mounting clamps secure to the PowerStation using a sliding mechanism. You must slide the feet of the mounting clamp into the appropriate slot on the PowerStation.

There are four styles of clamps used to mount the PowerStation to your enclosure depending on the display size. To mount the PowerStation properly, refer to the instructions below that corresponds with the display size you are using.

For your convenience, all necessary mounting hardware is included with the unit.

Mounting a PowerStation With a 6” Display

If you are mounting a PowerStation with a 6” display, complete the instructions below:

- 1 Slide the PowerStation into the cutout from the front.
- 2 Attach the 4 mounting clamps, with their screws to the back of the unit in the spaces provided. You will place 2 clamps on the top and bottom of the unit.

The clamps secure to the unit using the sliding mechanism shown in Figure 2-2.

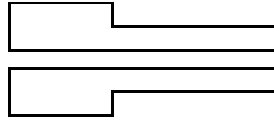
Figure 2-2: Sliding Mechanism for the 6" PowerStations

- 3 Slide the feet of the mounting clip into the slot, then slide the clip over to properly mount the unit.
- 4 Tighten each of the mounting screws against the front of the enclosure.
- 5 Torque them down to **6 in/lbs**.
- 6 Tighten the screws in a crosswise sequence to ensure a good seal and prevent damage. Tightening the bracket assembly may not ensure that the gasket seal is totally depressed by the bezel. You may see a small gap between the bezel and the enclosure.

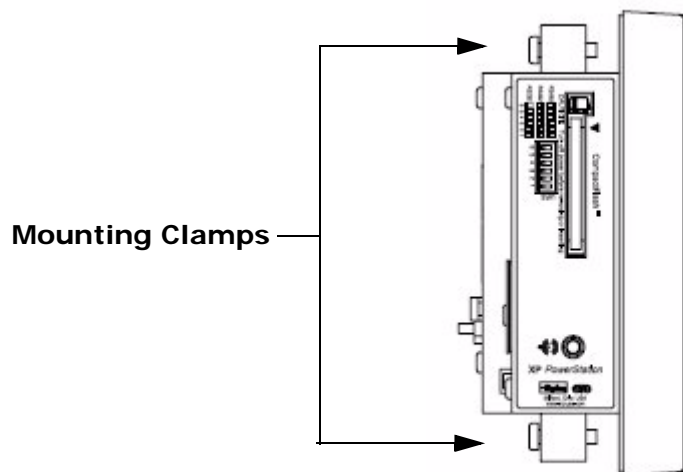

Mounting a PowerStation With an 8" Display

If you are mounting a PowerStation with a 8" display, complete the instructions below:

- 1 Slide the PowerStation into the cutout from the front.
- 2 Attach the 4 mounting clamps, with their screws to the back of the unit in the spaces provided. You will place 2 clamps on the top and bottom of the unit.

The clamps secure to the unit using the sliding mechanism shown in Figure 2-3.

Figure 2-3: Sliding Mechanism for the 8" PowerStations

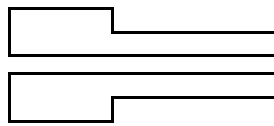

- 3 Slide the feet of the mounting clip into the slot, then slide the clip over to properly mount the unit.
- 4 Tighten each of the mounting screws against the front of the enclosure.
- 5 Torque them down to **7 in/lbs**.
- 6 Tighten the screws in a crosswise sequence to ensure a good seal and prevent damage. Tightening the bracket assembly may not ensure that the gasket seal is totally depressed by the bezel. You may see a small gap between the bezel and the enclosure.

Figure 2-4: Clamp Shape for an 8" PowerStation Display

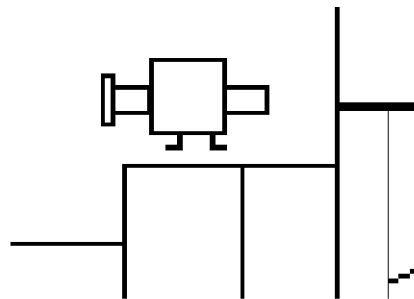
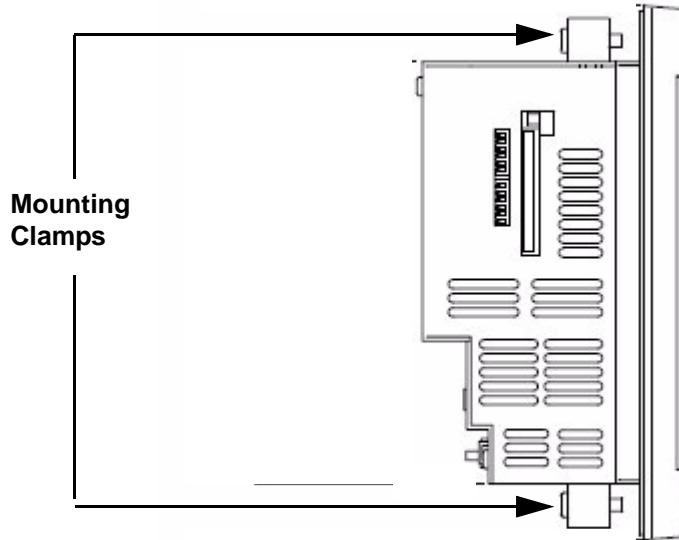

Figure 2-5: Clamp Location on an 8" PowerStation Display



Attach the power connector that you prepared in *Mounting the AC Power Supply* on page 2-15, to the back of the unit.

Mounting a PowerStation With a 10" Display

If you are mounting a PowerStation with a 10" display, complete the instructions below:

- 1 Slide the PowerStation into the cutout from the front.
- 2 Attach the 6 mounting clamps, with their screws to the back of the unit in the spaces provided. Place 2 clamps on the top and bottom of the monitor and 1 on each side.

The clamps secure to the unit using the sliding mechanism shown in Figure 2-6.

Figure 2-6: Sliding Mechanism for 10" PowerStations

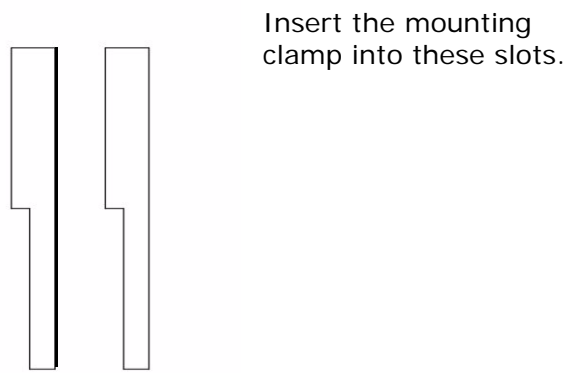

- 3 Insert the clamp into the wide end of the slot and slide it to the thin end, refer to Figure 2-7.

Figure 2-7: Side View of a 10" PowerStation Mounting Clamp

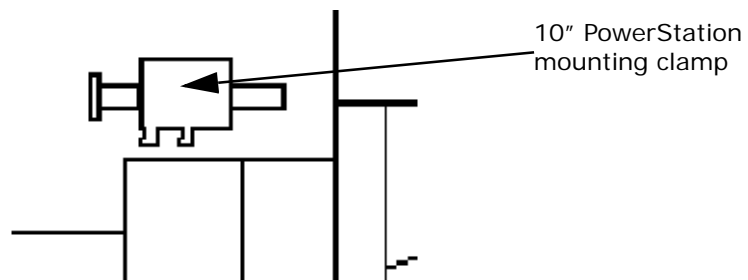
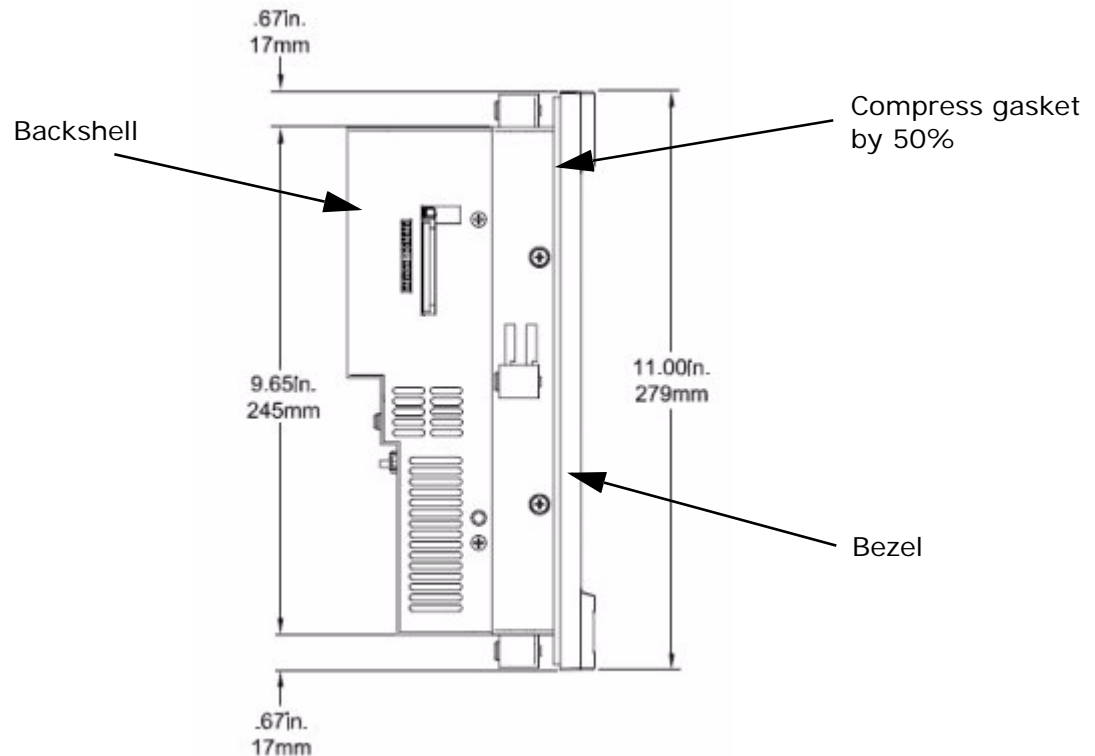

Figure 2-8: Side View of a 10" PowerStation Mounted in an Enclosure



- 4 Tighten each of the mounting screws against the front of the enclosure.
- 5 Torque the screws until the gasket is compressed by 50%.



Caution: Do not over-tighten the screw/clamp assembly or you may damage the monitor. However, under-tightening may not guarantee a NEMA 4/4x seal.

- 6 Tighten the screws in a crosswise sequence to ensure a good seal and prevent damage.

Note that tightening the bracket assembly may not ensure that the gasket seal is totally depressed by the bezel and flush with the enclosure. Since a proper NEMA 4/4x seal requires a 50% compression of the gasket, you may see a small gap between the bezel and the enclosure.

Mounting a PowerStation With a 15" Display

If you are mounting a PowerStation with a 15" display, complete the instructions below:

- 1 Slide the PowerStation into the cutout from the front.
- 2 Attach the 8 mounting clamps, with their screws to the back of the unit in the spaces provided. Place 2 clamps on the top and bottom of the monitor and 2 on each side.

The clamps secure to the unit using the sliding mechanism shown in Figure 2-9.

Figure 2-9: Sliding Mechanism for 15" PowerStations

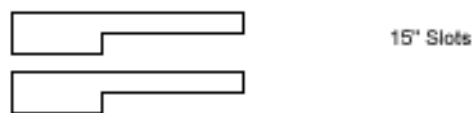

- 3 Insert the clamp into the wide end of the slot and slide it to the thin end, refer to Figure 2-11.

Figure 2-10: Side View of a 15" PowerStation Mounting Clamp

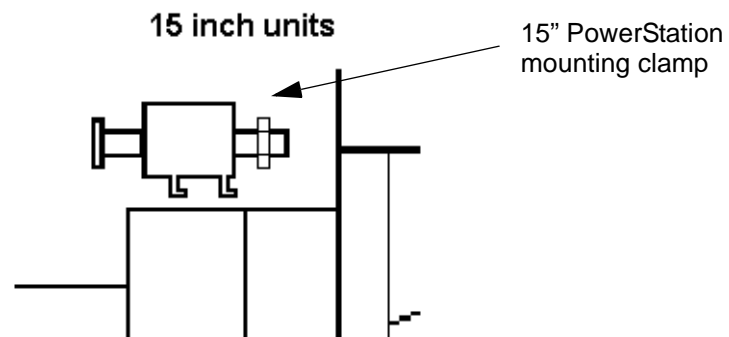
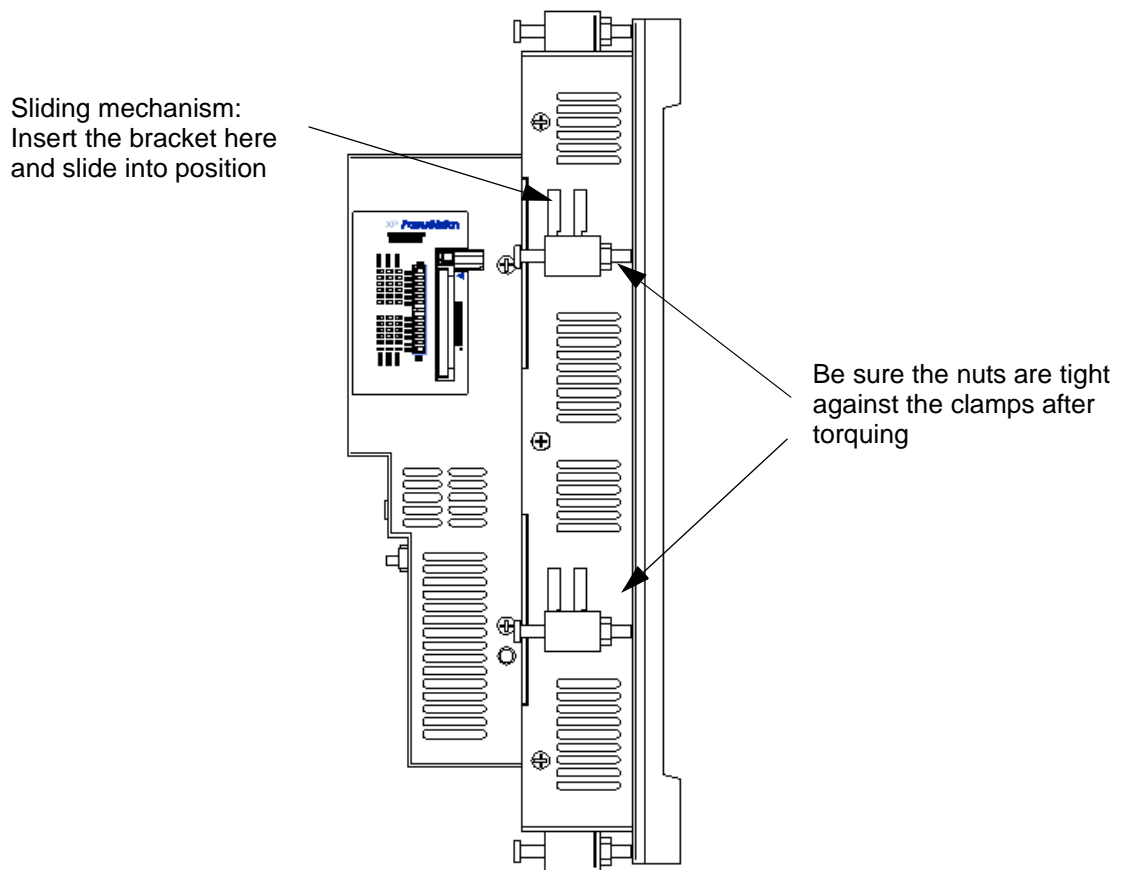

Figure 2-11: Side View of a 15" PowerStation Mounted in an Enclosure



4 Tighten each of the mounting screws against the front of the enclosure.

5 Torque them down to **7 in/lbs**.

Caution: Do not over-tighten the screw/clamp assembly or you may damage the monitor. However, under-tightening may not guarantee a NEMA 4/4x seal.

6 Tighten the screws in a crosswise sequence to ensure a good seal and prevent damage.

7 Adjust the nut so that it is firmly against the surface of the clamp to prevent loosening.

Note that tightening the bracket assembly may not ensure that the gasket seal is totally depressed by the bezel and flush with the enclosure. You may see a small gap between the bezel and the enclosure.



Installing an Optional AC Power Supply

The XP PowerStation uses DC power. However, you can operate the PowerStation with AC power by using an optional AC Power Supply available from Parker. Use this section only if you intend to operate the XP PowerStation using AC power. If you plan to use DC power, refer to *Installing the XP PowerStation* on page 2-7.



Caution: Do not apply AC power directly to the unit or damage may occur.

Preparing a Location for the AC Power Supply

Be sure to select a location that provides protection from dust, oil, moisture, and corrosive vapors. If your enclosure is large enough, you can mount the Power Supply in the enclosure with the unit.

If you purchased Parker's optional AC Power Supply and mounting kit, use the template that came with the mounting kit to prepare your location for the power supply. This can be inside or outside the enclosure where the PowerStation is installed.

Note: If you decide to mount the Power Supply in an enclosure, mount it on the bottom or on the side of the enclosure to provide the best convection cooling.

Prepare the Power Supply Mounting Surface

The AC power supply is designed to be mounted using two metal brackets. These brackets are secured to the mounting surface using four screws. To prepare the mounting surface, complete the following steps:

- 1 Measure the cutout dimensions.
- 2 Securely attach the power supply template to the mounting surface.
- 3 Cutout the four 0.17" (4.3mm) holes as shown on the template.
- 4 Debur the edges of the cutout area, removing dirt and debris.

Mounting the AC Power Supply

After drilling the holes for the four screws, you can follow the steps below to mount the power supply:

- 1 Disconnect the power cable from the AC power source.
- 2 Attach the power supply to the mounting surface using the supplied metal brackets.
- 3 Connect the power cord from the power supply to an AC power source.

- 4 Secure the power cable to the power supply using the supplied L-shaped metal bracket and nut.

Connecting the Power Supply to the Workstation

Once you have mounted the power supply, you are ready to connect it to the workstation.

- 1 Slide the positive and negative wires into the appropriate slots on the power connector that was shipped with the workstation. See Figure 2-12.

Figure 2-12: Power Connector and Positive/Negative Wires

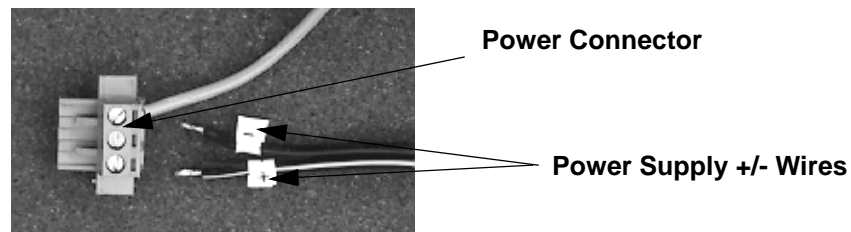

- 2 Connect the ground cable from the power connector to an earth ground.
- 3 Connect the power cord from the power supply to an AC power source.
- 4 Attach the power connector that you prepared in Step 1, to the workstation.

You have successfully connected the power supply to your workstation. You can now operate the workstation using AC power.



Caution: All XP units are powered from a 24VDC power source. DO NOT connect AC power to the unit.

STARTING YOUR POWERSTATION

3

This chapter discusses the following topics:

- The PowerStation Connectors
- Starting the PowerStation
- Using the CompactFlash Card
- Using the BIOS Utility with an XPx06 Unit
- Using the BIOS Utility with an XPx8, XPx10, or XPx15 Unit

The PowerStation is shipped with the XP PowerStation Documentation and Utilities CD. This CD contains all of the dimensional drawings, software, and drivers needed. If any of the software on your system becomes lost or corrupted, you can reinstall it from this distribution disk.

PowerStation Connectors

All XP PowerStations have the following connectors:

- 2 serial ports
- 2 USB ports for the keyboard and mouse
- 1 Ethernet port
- 1 Compact Flash connector
- Power switch/power button
- 1 ground stud

The XPx08, XPx10, and the XPx15 also have two PS/2 keyboard/mouse ports. See the XP PowerStation CD for dimensional drawings and a diagram to locate the components.

Serial Ports

The XP PowerStation has two serial ports that you can use to communicate with external devices at baud rates of up to 115 Kbaud.

The COM1 port supports RS-232, while COM2 supports configurable RS-232, RS-422, and RS-485 communication standards.

The communication standard you select for COM2 depends upon the distance between the XP PowerStation and the controller, as well as the communication standards that the controller supports. Use a standard DB9 connector for communicating with this port.

Note: If you are using RS-232 communications, the length of the serial cable should not exceed 50 feet (15 meters).

RS-422 and RS-485 communications offer greater noise immunity than RS-232. These standards increase the maximum cable length to 4,000 feet (1,200 meters).

RS-422 communications are full-duplex (send and receive simultaneously), while RS-485 communications are half-duplex (send or receive).

For either configuration, be careful not to connect any wires to unused connector pins.

Settings and Pinouts for COM1

If you need to make a cable for communicating with COM1, Table 3-1 shows the pinouts and signal information for this port.

Table 3-1: COM1 Pinouts

Pin#	Signal
1	DCD, data carrier detect
2	RXD, received data
3	TXD, transmitted data
4	DTR, data terminal ready
5	Signal ground
6	DSR
7	RTS, request to send
8	CTS, clear to send
9	RI

Settings and Pinouts for COM2 on the XPR00 & XPx06

If you are using the XPx06 and need to make a cable for communicating with COM2, Table 3-2, shows the pinouts and signal information for this port.

Table 3-2: COM2 Pinouts for the XPR00 & XPx06

Pin#	RS-232 Signal	RS-422 Signal	RS-485 Signal
1	N/C	TXD-, transmitted data -	TXD-, transmitted data -
2	RXD, received data	TXD+, transmitted data +	TXD+, transmitted data +
3	TXD, transmitted data	RXD+, received data +	RXD+, received data +
4	N/C	RXD-, received data -	RXD-, received data -
5	Signal ground	Signal ground	Signal ground
6	N/C	N/C	N/C
7	RTS, request to send	RTS, request to send	RTS, request to send
8	CTS, clear to send	CTS, clear to send	CTS, clear to send
9	N/C	N/C	N/C

If you need to make a cable for communicating with COM2, you may need to set the DIP switch settings.

COM2 is set to the RS-485 protocol by default. To change COM2 to the RS-232 or RS-422 protocol, you must change the COM2 DIP switch settings.

The DIP switch for COM2 is located on the side of the XP PowerStation Unit, as shown in Figure 3-1.

Figure 3-1: COM2 Dip Switch Settings for the XPR00& XPx06

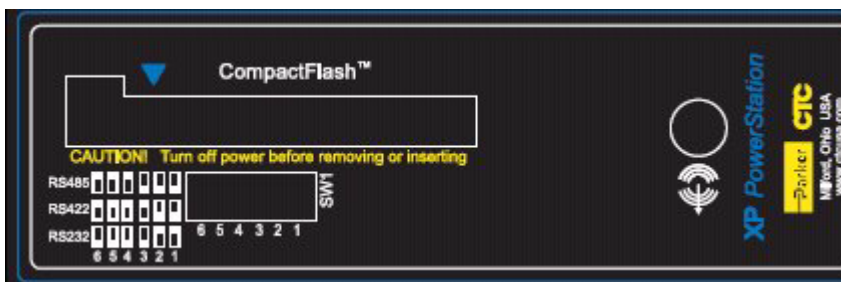

- The white boxes represent the tip of the switch.
- The upper half of the switch is the ON position, and the lower half of the switch is the OFF position.

To change the DIP switch settings, complete the following steps:

- 1 Choose the appropriate DIP switch settings from the diagram displayed on the side of the XP PowerStation.
- 2 Using a pointed instrument such as a pen or pencil, flip the switches to the appropriate settings through the viewing window.

Figure 3-2, displays the pinouts and cable settings required for communicating with COM1 or COM2 using the RS-232, RS-422 or the RS-485 protocol.

Figure 3-2: Pinouts and Cable Settings for the XPR00 & XPx06

RS-232	RS-422	RS-485
<p><u>COM1/COM2</u></p> <p style="text-align: right;">232</p>	<p><u>COM2</u></p> <p style="text-align: right;">422</p>	<p><u>COM2</u></p> <p style="text-align: right;">485</p>

Note: Be careful not to connect any wires to unused connector pins.

Settings and Pinouts for COM2 on the XPx08/XPx10/XPx15

If you need to make a cable for communicating with COM2, Table 3-3 shows the pinouts and signal information for this port.

Table 3-3: COM2 Pinouts for the XPx08/XPx10/XPx15

Pin#	RS-232 Signal	RS-422 Signal	RS-485 Signal
1	DCD, data carrier detect	TXD-, transmitted data -	TXD-, transmitted data -
2	RXD, received data	TXD+, transmitted data +	TXD+, transmitted data +
3	TXD, transmitted data	RXD+, received data +	RXD+, received data +
4	DTR, data terminal ready	RXD-, received data -	RXD-, received data -
5	Signal ground	Signal ground	Signal ground
6	DSR, data set ready	DSR, data set ready	DSR, data set ready
7	RTS, request to send	RTS, request to send	RTS, request to send
8	CTS, clear to send	CTS, clear to send	CTS, clear to send
9	RI	RI	RI

If you are using the XPx08/XPx10/XPx15 and need to make a cable for communicating with COM2, you may need to set the DIP switch settings.

COM2 is set to the RS-485 protocol by default. To change COM2 to the RS-232 or RS-422 protocol, you must change the COM2 DIP switch settings.

The DIP switch for COM2 is located on the side of the XP PowerStation, as shown in Figure 3-3.

Figure 3-3: COM2 Settings for XPx08/XPx10/XPx15

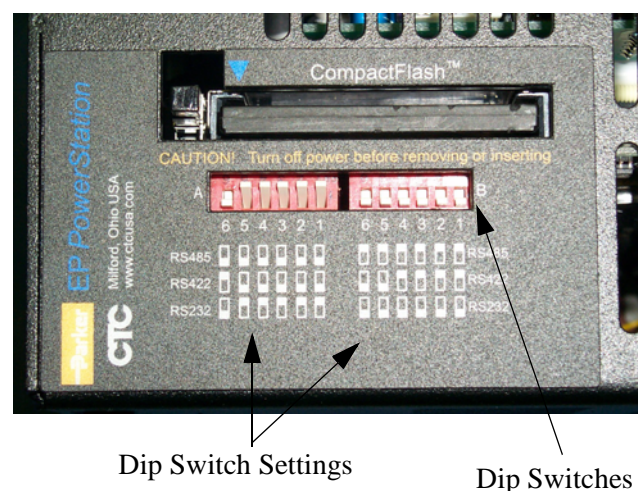
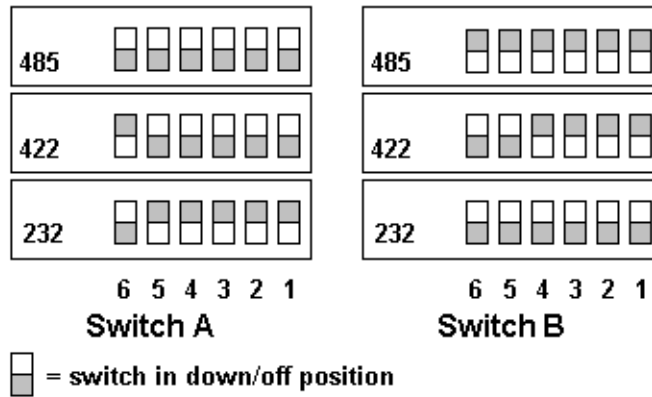

Figure 3-4, displays the settings for the COM2 port. A similar diagram is located on the side of the XP PowerStation next to the DIP switch cutout.

Figure 3-4: Dip Switch Settings for the XPx08/XPx10/XPx15



- The gray boxes represent the tip of the switch.
- The upper half of the switch is the ON position, and the lower half of the switch is the OFF position.

To change the DIP switch settings, complete the following steps:

- 1 Choose the appropriate DIP switch settings from the diagram displayed on the side of the XP PowerStation or from *Figure 3-4*.
- 2 Using a pointed instrument such as a pen or pencil, flip the switches to the appropriate settings through the viewing window.

Figure 3-5 displays the pinouts and cable settings required for communicating with COM1 or COM2 using the RS-232, RS-422 or the RS-485 protocol.

Figure 3-5: Pinouts and Cable Settings for the XPx08/XPx10/XPx15

RS-232	RS-422	RS-485
<p><u>COM1/COM2</u></p> <p>RXD 2 →</p> <p>TXD 3 →</p> <p>RTS 7</p> <p>CTS 8</p> <p>RI 9</p> <p>GND 5 →</p> <p>DCD 1</p> <p>DTR 4 →</p> <p>DSR 6</p> <p style="text-align: right;">232</p>	<p><u>COM2</u></p> <p>TXD- 1</p> <p>TXD+ 2</p> <p>RXD+ 3</p> <p>RXD- 4</p> <p>GND 5</p> <p>DSR 6</p> <p>RTS 7</p> <p>CTS 8</p> <p>RI 9</p> <p style="text-align: right;">422</p>	<p><u>COM2</u></p> <p>TXD- 1</p> <p>TXD+ 2</p> <p>RXD+ 3</p> <p>RXD- 4</p> <p>GND 5</p> <p>DSR 6</p> <p>RTS 7</p> <p>CTS 8</p> <p>RI 9</p> <p style="text-align: right;">485</p>

Note: Be careful not to connect any wires to unused connector pins.

RS-485 Directional Control on a 6" PowerStation

The RS-485 transceiver circuit has an automatic directional control feature. Normally the transceiver is waiting to receive data, but it will switch to transmit mode as soon as it senses data on the SOUT pin of the UART. It switches back to receive mode when data transmission is complete. This feature is optimized for baud rates of 9600 and greater.

RS-485 Directional Control on 8", 10", and 15" PowerStations

Many device drivers use the RTS signal to switch between receive and transmit mode. Some third party communication drivers expect the directional control to be automatic. Although most drivers will communicate fine in "Auto" mode, the directional control jumper allows the configuration of this port. The default setting of this jumper is "Auto".

Transferring Files from a PC to the XP PowerStation

You can transfer files from a PC to the XP PowerStation in one of three ways—through the Ethernet, the CompactFlash, or a Serial Transfer. If you plan to use a Serial Transfer, you will need a null modem cable. To construct your own cables, refer to Figure 3-6, for the appropriate settings. Then continue with step 1 below.

Figure 3-6: Serial Transfer Cable Diagram

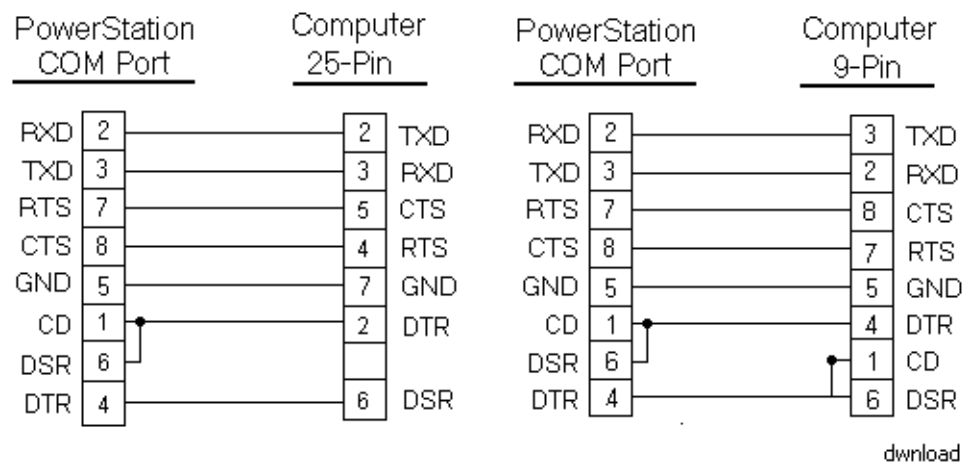

- 1 Connect a null modem serial cable to an available serial port on the IBM-PC.
- 2 Connect the other end of the cable to the serial port on the XP PowerStation.

Keyboard and Mouse Ports

The XP PowerStation allows you to use a keyboard and mouse in addition to the touchscreen. The PowerStation accepts any IBM AT-compatible keyboard, including 84-key standard keyboards and 101-key enhanced keyboards.

- **XPR00/XPx06:** These devices only accept a keyboard or mouse with a USB connector.
- **XPx08/XPx10/XPx15:** These devices accept a keyboard with a mini-din connector and a Microsoft PS/2-style mouse, specifically an 802.3 Microsoft-compatible mouse. These devices also accept a keyboard or mouse with a USB connector.

Be sure not to connect the mouse directly to the keyboard port, it will cause the mouse to malfunction.

Ethernet Port

The XP PowerStation has an Ethernet RJ45 port with an Intel 82551ER 10/100 Mbps base-T controller that allows you to connect the PowerStation to a Local Area Network.

Table 3-4: Ethernet Pinouts

Pin#	Signal
1	TX+
2	TX-
3	RX+
4	N/C
5	N/C
6	RX-
7	N/C
8	N/C

CompactFlash

The XP PowerStation comes with a CompactFlash (CF) card. The CF is used as a removable hard drive that is recognized as drive C and provides non-volatile memory storage. The CF is well-suited for rugged environments where the PowerStation may vibrate or shake. Although the CF is removable, it is used as an IDE drive, which means you cannot remove it while the PowerStation is switched on.

The XP PowerStation supports Type 1 or Type 2 CF cards.

You should purchase at least one additional CF card to serve as a backup for your primary CF card. It is also useful to own several cards to store different projects. You can purchase additional CF cards through Parker.

Note: Do not remove or insert the CF card when the unit is powered on or data on the card could be corrupted.

Starting the PowerStation

Once the XP PowerStation has been mounted, you are ready to start up the unit. This procedure is described below.

Before connecting a power cord to your unit, make sure that you have read and understood *Environmental Specifications* on page A-4, and the *Testing Specifications* on page A-6, of this manual. For **permanently connected equipment**, incorporate a readily accessible disconnect device in the fixed wiring.

Note: • Input voltage to the unit must be DC only.

- 1 Ensure the power on/off switch is in the off position.
- 2 Connect the power cord to your voltage source. Voltage input to the unit should be within the range specified in the *Environmental Specifications*.
- 3 Connect the power cord plug to the XP PowerStation.
- 4 Turn the XP PowerStation on.

If you have an XPR PowerStation, you are now ready to download a project.

Using the CompactFlash Card

The XP PowerStation uses a removable CompactFlash (CF) card for storage purposes. You can remove the CF card, update the application files on the CF card from a PC, and then reinstall the CF card in the PowerStation.

You should purchase at least one additional CF card to serve as a backup for your primary CF card. You can also have several cards to store different projects. You can purchase additional CF cards from Parker.

The XP PowerStation supports Type 1 or Type 2 CF cards.

Writing to the CompactFlash Card

To write to the CompactFlash card, you will need one of the following:

- A personal computer running Windows with a CD-ROM drive and a SanDisk ImageMate or any CompactFlash card PC reader/writer. A SanDisk ImageMate is a CompactFlash reader/writer that connects to the personal computer through a USB port. You can purchase a SanDisk ImageMate from any retail computer supply store.
- A laptop computer running Windows with a CD-ROM drive and a PCMCIA-to-CompactFlash adapter. The PCMCIA-to-CompactFlash adapter lets you read from or write to a CompactFlash card through your laptop's PCMCIA slot. You can order a PCMCIA-to-CompactFlash adapter (model number FLH-ADPT-2000) from your local Parker distributor.

Using the BIOS Utility

This section discusses how to use the BIOS utility on the PowerStation. There are three instances in which you will need to use the BIOS utility program:

- 1 You are starting your system for the first time.
- 2 You have changed the hardware attached to your system.
- 3 The CMOS memory has lost power and the configuration information has been erased.

Every computer with a motherboard includes a special chip referred to as the BIOS or ROM BIOS (*Read Only Memory Basic Input/Output System*). The BIOS includes instructions to interact with the computer hardware. It also includes a test which ensures that the computer meets requirements to boot up properly. If the computer encounters an error during the test, you either hear a combination of beeps or see an error message on the screen.

Error messages can be fatal or non-fatal. Generally, the system can continue the boot up sequence with a non-fatal error. These are usually displayed on the screen along with the following instructions:

Press <F1> to RESUME

Write down the error message and press the F1 key to continue booting the system. If you want to change BIOS settings, refer to the following sections appropriate to the PowerStation you are using.

Using the BIOS Utility with an XPx06 Unit

This section is for use with an XPx06 PowerStation only. For information on setting up the BIOS for an XPx08, XPx10, or XPx15 PowerStation, refer to page 3-14.

Entering Setup

Before changing any of the BIOS settings, shut down the system and connect a keyboard to the PowerStation.

- 1 Turn on the PowerStation.
- 2 Press the **F1** key while the system splash screen displays to enter the BIOS setup utility.

When the BIOS utility is displayed, press a letter key or use the arrow keys to navigate through the menu. The following options are available:

- **Motherboard Device Configuration**
Allows you to configure serial and parallel ports on an LPC card.
- **Miscellaneous Configuration**
Allows you to display a splash screen and/or a summary screen. The timeout field sets the time for how long the screen is displayed. The time is in milliseconds and goes from 0 to 65535. Enter a timeout interval and press the Enter/Return key.
- **Boot Order**
Allows you to alter the devices checked for a bootable image. The options are: Floppy Disk, Hard Drive, CD-ROM Drive and USB Floppy Disk. Use the arrow keys to select the order number and then press Enter to cycle through the options.
- **Load Defaults**
Loads the default BIOS settings.
- **Save Values Without Exit**
Saves the current BIOS settings without exiting the utility.
- **Exit Without Save**
Exits the BIOS utility without saving any changes made.
- **Save Values and Exit**
Exits the BIOS utility after saving any changes made.

Using the BIOS Utility with an XPx8, XPx10, or XPx15 Unit

This section is for use with an XPx08, XPx10, or XPx15 PowerStation only. For information on setting up the BIOS for an XPx06 PowerStation, refer to page 3-12.

You can use the BIOS utility to perform the following functions on your PowerStation:

- Basic system configuration (date, time, IDE, etc.)
- Change the values in the chipset registers
- Specify settings for integrated peripherals, power management, and frequency and voltage control
- Set the shutdown temperature and load values for minimal operating performance
- Optimize and load default BIOS settings

Navigating the BIOS Utility

Each section of the BIOS utility is broken into multiple pages to offer more available options and make it easier to locate information.

Navigating the BIOS program is fairly straight forward, see the table below for details.

Table 3-5: Navigation Keys in the Phoenix-Award BIOS Utility

Key	Action
arrow keys	Moves between the available options on the screen.
+, -, Page Up, Page Down, or Enter	Changes a value in the BIOS utility.
Esc	Exits from a menu in the BIOS utility.
F10	Saves the changed value and exits the CMOS setup.

Entering Setup

Before changing any of the BIOS settings, shut down the system and connect a keyboard to the PowerStation.

- 1 Turn on the PowerStation.
- 2 Press **Del** immediately to allow you to enter the BIOS setup utility. The Phoenix - Award BIOS main menu is displayed as shown in Figure 3-7.

Figure 3-7The Phoenix - Award CMOS Setup Utility Main Menu

The main menu allows you to access each of the other submenus in the BIOS utility. Table 3-6, briefly describes each menu option.

Table 3-6: BIOS Menu Options

Menu Option	Description
Standard CMOS Features	Use this menu for basic system configuration such as setting the date, time, IDE, etc.
Advanced BIOS Features	Use this menu to set advanced features available on your system such as virus warnings.
Advanced chipset Features	Use this menu to change the values in the chipset registers and optimize your system performance.
Integrated Peripherals	Use this menu to specify your settings for integrated peripherals (primary slave, secondary slave, keyboard, mouse, etc.).
Power Management Setup	Use this menu to specify your settings for power management (HDD power down, power on by ring, KB wake up, etc.).
PnP/PCI Configurations	This menu is available only if your system supports PnP/PCI.
PC Health Status	Use this menu to set the shutdown temperature for your system.

Menu Option	Description
Frequency/Voltage Control	Use this menu to specify your settings for frequency/voltage control.
Load Fail-safe Defaults	Use this menu to load the BIOS default values for the minimal/stable operational performance for your system.
Load Optimized Defaults	Use this menu to load the BIOS default values that are factory settings for optimal performance. You can customize the BIOS to maximize performance.
Set Supervisor Password	Use these menus to set supervisor and user passwords.
Set User Password	
Save & Exit Setup	Use this option to save CMOS value changes and exit the setup utility.
Exit without Saving	Use this option to exit the setup utility without saving value changes.

The following sections discuss the BIOS options you are more likely to use. For more detailed information, see the documentation for the BIOS utility.

Resetting Disk Boot Priority

The system will try to boot from the First Boot Device, then the Second Boot Device, and finally the Third Boot Device as listed in the BIOS Setup utility. You can assign disk boot priority in any order.

To reset the disk boot priority, complete the following steps from the BIOS Setup utility main screen:

- 1 Select **Advanced BIOS Features**.
- 2 Scroll down the list of options and select either **First Boot Device**, **Second Boot Device**, or **Third Boot Device** depending on which device you wish to configure.
- 3 A list of all the available boot options displays.
- 4 Scroll down the list and select the device the system will use to boot up.
For example, if you want to boot to a USB device you can select from 1 of 4 USB devices. You can select USB-FDD, USB-ZIP, USB-CDROM, or USB-HDD.
- 5 Once you select your boot device, press **Enter**.
- 6 Press **Esc** to return to the main menu.
- 7 Press **F10** to save any changes and exit the BIOS Setup utility. Your system will boot to the selected device.

Load Optimized Defaults

Use this option if you want to reload the default BIOS values that are factory settings for optimal performance.

- 1 Select **Load Optimized Defaults** from the main BIOS menu.
- 2 Press **Yes** at the prompt to return to default settings.
- 3 Press **Esc** to return to the main menu.

MAINTAINING THE POWERSTATION

The PowerStation has been designed to provide years of trouble-free operation even in the harshest environments. However, occasionally you need to perform routine maintenance on some of the units components.

This chapter provides instructions on maintaining your PowerStation:

- Maintaining the Touchscreen
- Replacing the CompactFlash
- Performing Internal Maintenance
- Optional Components
- Accessing the PowerStation Utilities

Maintaining the Touchscreen

This section discusses the basic maintenance of your PowerStation's touchscreen, including:

- Cleaning the Touchscreen
- Calibrating the Touchscreen

Cleaning the Touchscreen

Occasionally, you may need to clean the monitor's screen. Clean the screen using warm, soapy water and a cloth. You can also use any non-abrasive cleaner. See *Faceplate Chemical Resistance* on page A-7, for a list of substances the screen can resist with no visible effect.

Do not use any harsh material or powder, such as steel wool or abrasive cleansers, to clean the screen surface. The surface is sensitive to scraping, sharp blows, or punctures. Therefore, keep screwdrivers or other sharp objects away from the screen surface.



Warning Do **not** clean the unit while it is running. Turn off the monitor before cleaning it in order to avoid inadvertently activating the touchscreen.

Calibrating the Touchscreen

Calibrating the touchscreen ensures that it is aligned with your display. The monitor's touchscreen is calibrated before leaving Parker-CTC. However, you may need to recalibrate the touchscreen in certain circumstances, such as:

- Using the XP PowerStation for the first time
- Connecting the XP PowerStation to a new computer
- Using a remote, stand-alone configuration, or
- Whenever the cursor does not follow the touches on the screen.
- After reflashing an image to a compact flash card.

Calibrating the Touchscreen on a Windows CE PowerStation with Interact Xpress

The Interact Xpress software comes with a calibration utility located in the Shell. To calibrate the touchscreen, complete the following steps:

- 1 From the **Xpress Shell** main page, select the *Settings* button. The Settings page is displayed.
- 2 From the **Settings** page, select the *Calibrate Touchscreen* button. A prompt is displayed asking if you are sure you want to calibrate the touchscreen.
- 3 Click **OK** from the upper, right-hand corner of the dialog box to initiate the calibration routine.

Follow the directions on the screen, using your finger to touch on the screen as directed.

Calibrating the Touchscreen on a Windows CE PowerStation without Interact Xpress

To calibrate the touchscreen on a Windows CE PowerStation without Interact Xpress, complete the following steps:

- 1 Select **Start** → **Programs** → **TSHARC Calibration**.
- 2 Select **Calibrate**.
- 3 Click the center of where the arrows are pointing. The Calibration screen appears.
- 4 Touch the target where it appears on the screen, hold your finger there momentarily, and then release. The screen guides you through the Touch - Hold - Release process.
- 5 Repeat the process three more times in the other three corners of the screen. A test screen appears.
- 6 Move your finger across the monitor. The target should move with your finger. If so, the calibration was successful.
- 7 Select **Accept**.

Note If the touchscreen still does not appear calibrated, and the cursor moves vertically when your finger moves horizontally on the screen or vice versa, the touchscreen cable may not be connected to the motherboard properly. Call a CTC customer service representative.

Calibrating the Touchscreen on a Windows XP PowerStation

To calibrate the Hampshire touchscreen driver under Windows 2000 and XP Professional, complete the following steps:

- 1 Select **Start** → **Programs** → **Hampshire**. You may also select the **Calibrate Touchscreen** on the desktop. The Hampshire TSHARC Control Panel appears.
- 2 Follow the on screen instructions for selecting which monitor to calibrate.
- 3 Select the **Calibrate** tab.
- 4 Click the center of where the arrows are pointing. The Calibration screen appears.
- 5 Touch the target where it appears on the screen, hold your finger there until prompted to release. The screen guides you through the *Touch - Hold - Release* process.
- 6 Repeat the process three more times in the other three corners of the screen. A test screen appears.
- 7 Move your finger across the monitor. The target should move with your finger. If so, the calibration was successful.
- 8 Select **Accept**.
- 9 On the control panel, select **Apply** and then select **OK**.

Replacing the CompactFlash

At some point, you will probably need to remove the CompactFlash (CF) card from the XP PowerStation flash socket for one reason or another. To do so, complete the following steps:

- 1 Turn off the XP PowerStation.

Caution: The PowerStation must be turned off when inserting or removing the CF card to avoid corrupting data.

- 2 Locate the ejector next to the CF socket as shown in Figure 4-1.

Figure 4-1: CompactFlash Ejector.

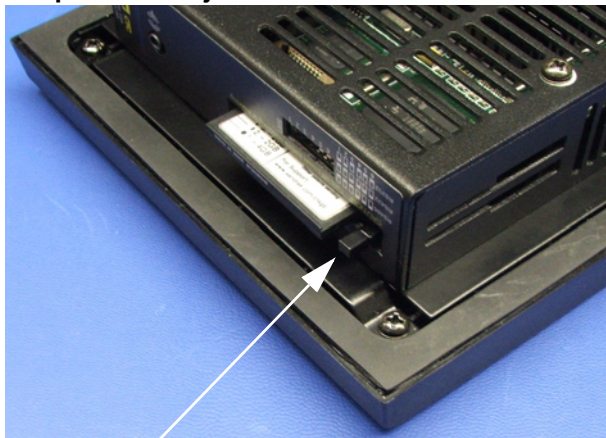

Ejector Button

- 3 Push the ejector button two times, once to extend the button, then again to pop out the CF card.
- 4 Remove the CF card.
- 5 Carefully insert the new card with the connector on the card aligning with the pins inside the socket.
- 6 Push the CF card into the slot until the card is securely seated in the socket. Do not force!

Note: The CompactFlash has an arrow near one edge that always lines up with a matching arrow on the label of the XP PowerStation. Insert the CompactFlash so the arrows line up and the card seats properly. **Do not** force the CompactFlash in the wrong way.

If you need additional storage capacity for the XP PowerStation, you can purchase additional CompactFlash cards from Parker. Be sure to purchase at least one additional flash card to serve as a backup for your primary CF.

Performing Internal Maintenance

Before doing any internal maintenance, be sure to read and understand the following procedures to prevent injury to yourself and/or damage to the PowerStation.

- Electrostatic Discharge (ESD) Precautions
- Removing the XP PowerStation from an Enclosure
- Opening the PowerStation
- Replacing the Fuse

Important: For safety reasons, the PowerStation should be opened *only* by qualified service personnel.

Electrostatic Discharge (ESD) Precautions



Modern integrated electronic devices, including the PowerStation, are extremely sensitive to electrostatic discharges (ESD) and fields. Before you open the system, be sure to follow these simple precautions to protect you and the PowerStation from harm resulting from ESD.

- Always disconnect power from the PowerStation before opening. **Do not** touch any components of the PowerStation while the system is on.
- Disconnect power before performing any internal maintenance or troubleshooting.
- Only handle internal components of the PowerStation in an ESD-safe location, using appropriate grounding methods.
- Wear a grounding wrist strap for continuous protection.
- Be particularly careful not to touch the components on the printed circuit boards.
- Keep any PowerStation part in its anti-static packaging when it is not installed in the unit and place it on a static dissipative mat when you are working on it.

Removing the XP PowerStation from an Enclosure

To remove the PowerStation from it's enclosure, follow the steps below.



WARNING!

Explosion Hazard!

- Do not connect or disconnect cables unless the power has been switched off, or the area is known to be safe.

- 1 Turn off the power to the unit.
- 2 Disconnect all cables:
- 3 Take off the clamps.
- 4 Place the PowerStation face down on a static dissipative mat, in a location free from dirt and moisture and protected against static discharge.

Opening the PowerStation

Once you have removed the PowerStation from it's enclosure, you can open it up. Follow the steps below.

- 1 Remove the CompactFlash card from it's slot by pressing the eject button on the side of the PowerStation, as shown below.

Figure 4-2: Eject Button

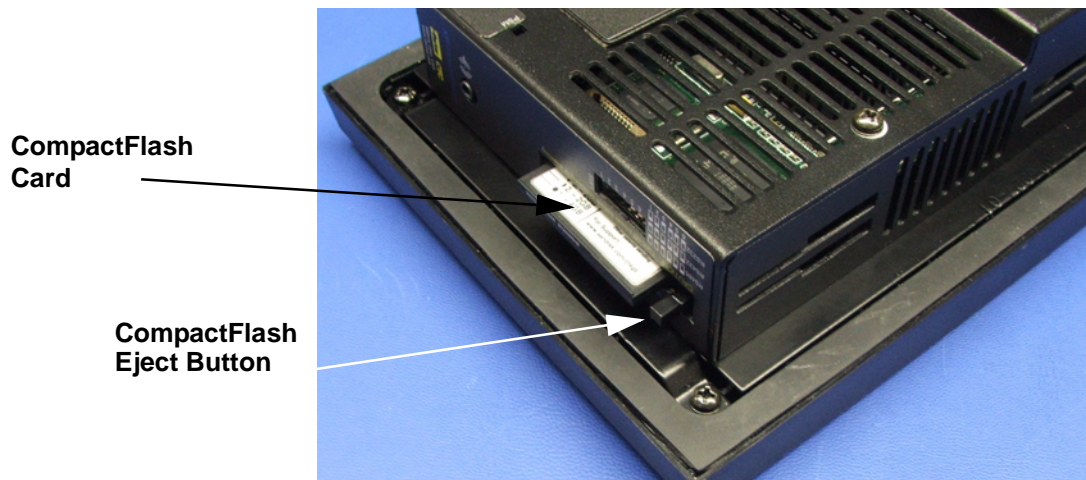

- 2 Press in the eject button to return it to it's retracted position.
- 3 Remove the screws on the XP PowerStation. If you are working with a 6" PowerStation, there are 4 screws to remove as shown below.

Figure 4-3: Backshell Screws

Remove these screws from the back of the PowerStation.

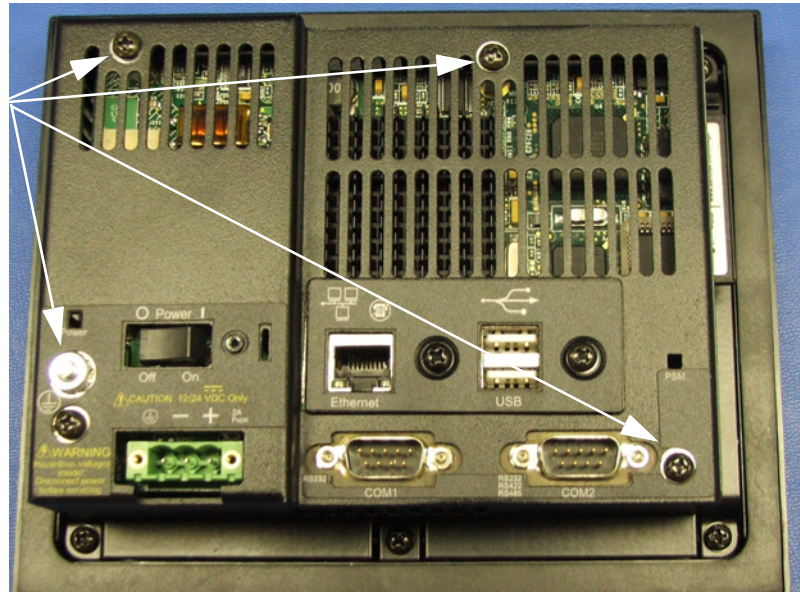

- 4 Lift the backshell off of the PowerStation to expose the board.

You are now ready to perform any internal maintenance necessary.

For 6" XP PowerStations Only

If you are using a 6" PowerStation, when you lift the backshell off of the unit the USB ground comes off of the backshell. You may find it on the board as shown below.

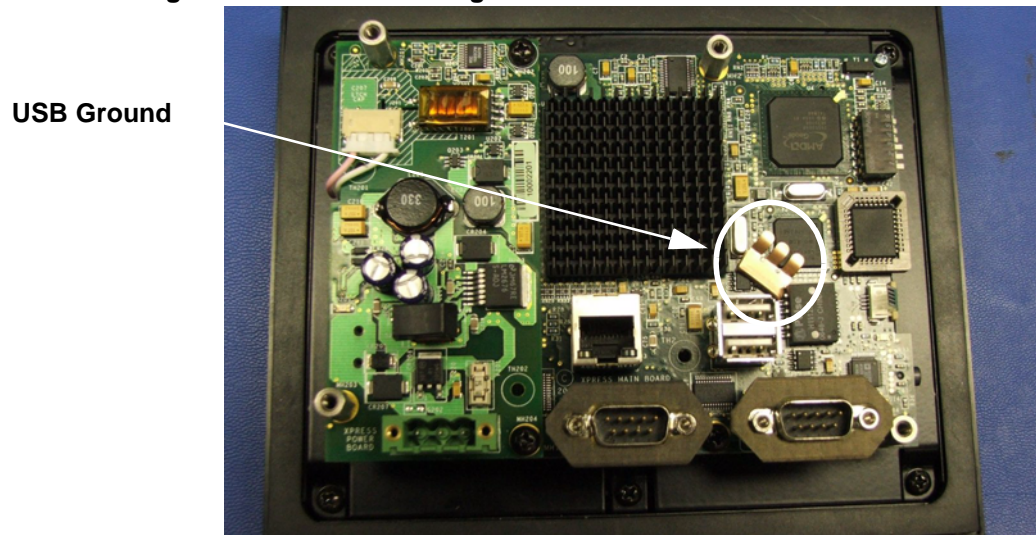
Figure 4-4: USB Grounding on XPx06

Simply replace the USB ground by clipping it on the inside of the backshell, refer to Figure 4-5.

Figure 4-5: Replacing the USB Ground on the 6" Backshell

The USB ground is replaced on the inside of the backshell.

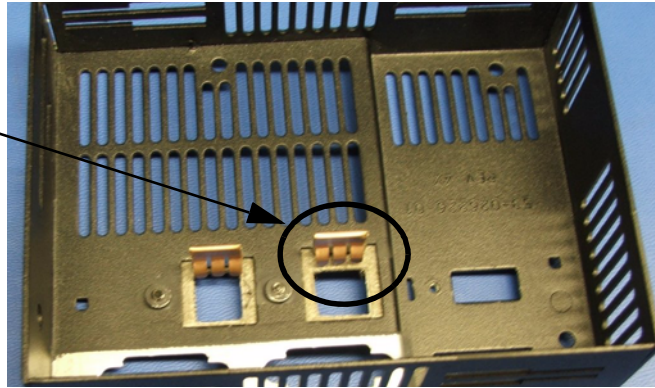

Closing the PowerStation

- 1 If you are using a 6" PowerStation, replace the USB ground on the inside of the backshell as discussed on page 4-7.
- 2 Replace the backshell on the PowerStation, refer to steps 3 and 4 on page 4-7.
- 3 Remount the PowerStation in the enclosure, refer to *Installing the XP PowerStation* on page 2-7.
- 4 Reconnect all cables:
- 5 Turn on the PowerStation.

Replacing the Fuse

The XP PowerStation has a protective fuse that you can replace by opening up the back cover. An ohm meter is required to see whether the fuse is open or closed.

- 1 Select the XP PowerStation you are using:

If you are using...	Then, to replace the fuse...
XPx06	Use a Littelfuse Nano SMF Slow Blow Type fuse. The part number is R454 002.
XPx08/XPx10/ XPx15	Use a Littelfuse Nano SMF Very Fast-Acting Type fuse. The part number is R451 004.



Caution: Using a fuse that is rated differently than indicated, can cause damage or fire to occur.

Replacing the Fuse on an XPx06 PowerStation

To replace the fuse, complete the following steps:

- 1 Remove the PowerStation from its enclosure as discussed on page 4-6.
- 2 Open the PowerStation, refer to page 4-6.
- 3 Locate the fuse on the board according to the picture below.

Figure 4-6: Fuse Location on XPx06

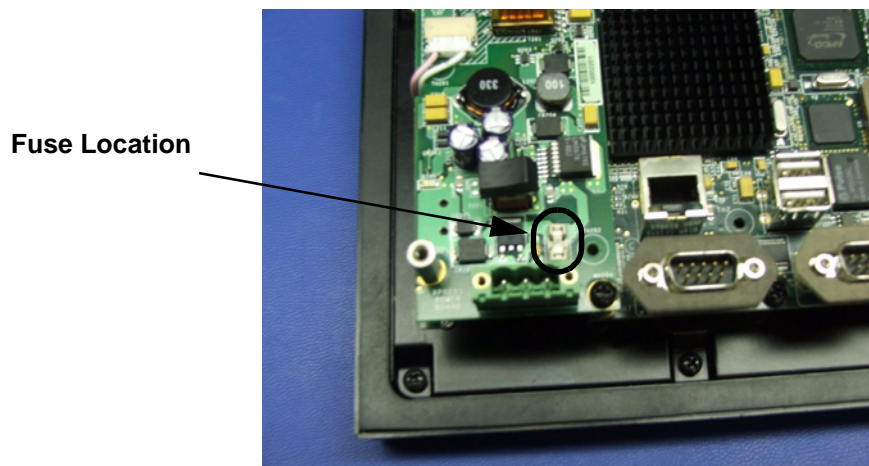

- 4 Use an ohm meter to see if the fuse is open or closed.
 - If open, use a pair of needle nose pliers to lift the fuse from the fuse holder.
 - If closed, the fuse is okay and there is no need to replace it.
- 5 Insert the new fuse into the fuse holder and reassemble the unit.

Replacing the Fuse on an XPx08, XPx10, or XPx15 PowerStation

To replace the fuse, complete the following steps:

- 1 Turn off the XP PowerStation.
- 2 Disconnect the PowerStation from its power source.
- 3 Remove the back cover of the unit.
- 4 Locate the fuse on the board according to the picture below.

Figure 4-7: Fuse Location XPx08, XPx10, or XPx15

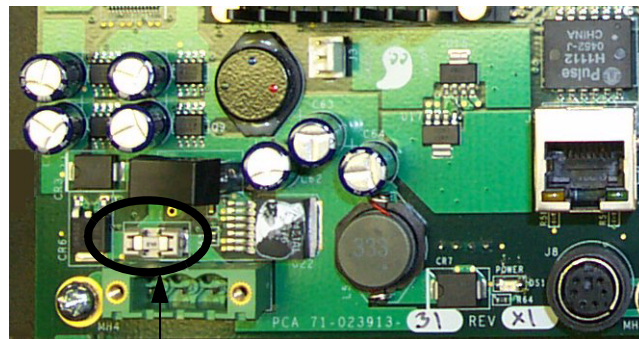

fuse location

- 5 Use an ohm meter to see if the fuse is open or closed. If open, use a pair of needle nose pliers to lift the fuse from the fuse holder. If closed, the fuse is okay and there is no need to replace it.
- 6 To replace the fuse, use a Littelfuse Nano SMF Very Fast-Acting Type fuse. The part number is R451 004.

Note: This is a 4 amp fuse. Using a fuse that is rated differently than indicated here can cause damage or fire to occur.

- 7 Insert the new fuse into the fuse holder and reassemble the unit.

Optional Components

Parker has an optional component that you may want to purchase for the XP PowerStation—a model P1X-PWRAC Power Supply.

AC Power Supply

The XP PowerStation uses DC power to save space and limit the amount of heat generated by the unit. However, if you require the PowerStation to use AC power, you can purchase an AC Power Supply kit that includes an AC Power Supply and a power cord.

You can also purchase mounting brackets for the Power Supply. See *Preparing a Location for the AC Power Supply* on page 2-15 for instructions on how to mount the AC Power Supply.

Note: Do not apply AC power directly to the unit or damage could occur.

Accessing the PowerStation Utilities

The XP PowerStation is shipped with the XP PowerStation Documentation and Utilities CD. This CD contains all of the dimensional drawings, software, and drivers needed for the XP PowerStation.

If any of the software on your system becomes lost or corrupted, you can reinstall it from this distribution disk.

Reinstalling Microsoft Windows on an XPC PowerStation

If you purchased an XPC PowerStation with a Windows XP Operating System installed, the XPC Documentation and Utilities CD contains the necessary system drivers for reinstallation of the operating system.

Please refer to the main menu of the CD to locate these drivers.

Recovery software on systems containing hard drives

The XPC PowerStations containing hard drives have a disk recovery software already installed; the Acronis True Image OEM. This software solves most backup problems by ensuring the safety of all information on the XPC unit. You can backup selected files and folders, Windows application settings, Microsoft email settings and messages, or entire disks and partitions.

If a failure occurs that blocks access to information or affects system operation or if files are accidentally deleted, you can easily restore the system and any lost data.

In order to recover the original factory image:

- 1 Reboot the PowerStation.
- 2 Press F11 when the option to start the Acronis OEM Zone software is displayed on the screen.

Note: You can also find a copy of the recovery CD image in the *recoveryimagexx.iso* file under the C:\ directory.

Refer to the *Acronis User Guide* located on the XPC Documentation and Utilities CD for specific operating instructions.

Ordering Replacement Components

The XP PowerStation is designed to be a simple yet reliable unit to maintain. However, if you need to purchase replacement components for

the PowerStation, Parker-CTC carries a complete line of replacement components.

Component	
CompactFlash (CF) card	<p>If you need additional storage capacity, you can purchase additional Compact Flash cards from CTC.</p> <p>You should purchase at least one additional compact flash card to serve as a backup for your primary CF.</p> <p>See page 4-4, for instructions on how to replace CF cards.</p>
DRAM	<p>If you need to upgrade or replace the DRAM, CTC carries replacement DRAM (DDR DIMM).</p> <p>Depending on the model ordered, the XP PowerStation comes with a minimum of 256MB DDR DRAM. The XPx00/XPx06 supports a maximum of 1GB DDR DRAM while the XPx10/XPx15 supports a maximum of 512MB DDR DRAM.</p>
Backlight bulb	<p>You can only replace the backlight bulb on the 10" XP PowerStation. You can send the PowerStation to CTC's repair center for bulb replacement. See <i>Customer Support Services</i> on page 1-4 for details.</p>
Fuse	<p>XPx06: Littelfuse Nano SMF Slow Blow Type fuse. The part number is R454 002.</p> <p>XPx08/XPx10/XPx15: Littelfuse Nano SMF Very Fast-Acting Type fuse. The part number is R451 004.</p>

POWERSTATION SPECIFICATIONS



This appendix outlines important specifications for the PowerStation. It is a good idea to familiarize yourself with the specifications before operating your unit.

- Physical Specifications
- Display Specifications
- Environmental Specifications
- Electrical Specifications
- Testing Specifications
- Faceplate Chemical Resistance

Physical Specifications

Physical specifications include the PowerStation's CPU, memory specifications, display types, storage capacity, and other physical characteristics. These specifications are shown in Table A-1, below.

Table A-1: Physical Specifications

Category	XPR00/XPx06	XPx08 XPx10 XPx15
Operating System	Microsoft Windows CE 5.0	Microsoft Windows CE 5.0
CPU	<ul style="list-style-type: none"> • AMD LX800 CPU, 500 MHz • 256KB L1 & L2 Cache 	<ul style="list-style-type: none"> • 650 MHz ultra low voltage Intel Celeron processor • 256 KB L2 cache • 100 MHz Front Side Bus
Memory	<ul style="list-style-type: none"> • Up to 1GB DDR SDRAM • 400 MHz, PC 3200 • 200-pin SODIMM Socket 	<ul style="list-style-type: none"> • 512 MB PC100 SDRAM • 144 Pin SODIMM Socket
BIOS	<ul style="list-style-type: none"> • Insyde XpressROM 	<ul style="list-style-type: none"> • PHOENIX/Award
Storage	<ul style="list-style-type: none"> • 128MB - 8GB CompactFlash card • Supports Type 2 CompactFlash cards 	<ul style="list-style-type: none"> • 128MB - 8GB CompactFlash card • Supports Type 2 CompactFlash cards
I/O Ports	<ul style="list-style-type: none"> • Two 9-pin serial ports (16550 compatible) <ul style="list-style-type: none"> • 1 RS232 • 1 RS232/422/485 (configurable) • One RJ45 Ethernet connector; Intel 82551ER 10/100 Base-T controller • Two USB 2.0 ports for the XPx06VT 	<ul style="list-style-type: none"> • Two 9-pin serial ports (16550 compatible) <ul style="list-style-type: none"> • 1 RS232 • 1 RS232/422/485 (configurable) • Two USB 1.1 host ports • One RJ45 Ethernet connector; Intel 82551ER 10/100 Base-T controller
Dimensions H x W x D	<ul style="list-style-type: none"> • XPR00: 5.33"H x 6.05" W x 2.51" D • XPx06: 6.00"H x 7.40"W x 3.00"D 	<ul style="list-style-type: none"> • XPx08: 7.6"H x 10.2"W x 3.8"D (overall depth) • XPx10: 11.0"H x 13.8"W x 4.7"D (overall depth) • XPx15: 13.31"H x 16.81"W x 5.24"D (overall depth)
Weight	<ul style="list-style-type: none"> • XPR00: 1.70 lbs/.77 kgs • XPx06: 2.56 lbs/1.16 kgs 	<ul style="list-style-type: none"> • XPx08: 6.08 lbs/2.75 kgs • XPx10: 9.48 lbs/4.30 kgs • XPx15: 15.68 lbs/7.11 kgs
Keyboard	<ul style="list-style-type: none"> • USB keyboard only 	<ul style="list-style-type: none"> • 1 PS/2 miniDIN
Mouse	<ul style="list-style-type: none"> • USB mouse only 	<ul style="list-style-type: none"> • 1 PS/2 miniDIN
Touchscreen	<ul style="list-style-type: none"> • Analog Resistive 	<ul style="list-style-type: none"> • Analog Resistive
Audible	<ul style="list-style-type: none"> • Piezoelectric Beeper • AC97 stereo output • 125" mini plug 	<ul style="list-style-type: none"> • Piezoelectric Beeper

Display Specifications

Display specifications include the type of monitor, size, resolution, and other display properties. These specifications are shown in the following table.

Table A-2: Display Specifications

Property	XPR00	XPx06VT	XPx08VT	XPx10VT	XPx10ST	XPx15XT
Type	No Display	Active Color TFT	Active Color TFT	Active Color TFT	Active Color TFT	Active Color TFT
Display Diagonal Size	N/A	5.7"	8.0"	10.4"	10.4"	15.0"
Resolution	N/A	VGA (640 x 480)	VGA (640 x 480)	VGA (640 x 480)	SVGA (800 x 600)	XGA (1024 x 768)
Brightness	N/A	350 NITS	380 NITS	350 NITS	350 NITS	260 NITS
Bulb Life	N/A	75,000 hours	10,000 hours	50,000 hours	50,000 hours	50,000 hours
Viewing Angle						
Left/Right	N/A	80°/80°	65°/65°	70°/70°	70°/70°	80°/80°
Up/Down	N/A	80°/70°	65°/55°	40°/70°	40°/70°	55°/80°

Environmental Specifications

Even though the XP PowerStation is built to withstand harsh environments, limit the PowerStation's exposure to adverse conditions such as dust, oil, moisture, and corrosive vapors to minimize maintenance and repair costs.

Remember that the temperature within a protective enclosure is generally higher than the external temperature. Thus, if the XP PowerStation is operating inside an enclosure at temperature levels above its rated ambient temperature, you must cool the enclosure. The PowerStation conforms to the environmental specifications listed in Table A-3.

Table A-3: Environmental Specifications Chart

Category	Specifications
Operating Temperature	32 to 122°F (0 to 50°C) ambient (air temp. outside of XP backshell)
Storage Temperature	<ul style="list-style-type: none"> • XPx00/XPx06: -22 to 176°F (-30 to 80°C) • XPx08/XPx10/XPx15: -4 to 140°F (-20 to 60°C)
Relative Humidity	0% to 95% non-condensing
Shock Rating	<ul style="list-style-type: none"> • 10g peak; 11ms (operating) • 30g peak; 11ms (non-operating)
Operating Vibration	<ul style="list-style-type: none"> • 5-500Hz: 0.5 grms random
Faceplate Design	<p>Tested for UL Type 4/4X or Type 12 (optional) Environment</p> <p>Warning: The PowerStation is rated NEMA Type 4/4X or Type 12 only if it is installed in a NEMA 4/4X or Type 12 rated enclosure.</p>

Electrical Specifications

The XP PowerStation's power supply automatically detects the input voltage level and adjusts accordingly. However, always use reliable sources of power, and isolate all communication cables from AC power lines to enhance noise immunity.

If possible, locate the XP PowerStation away from machinery that produces intense electrical noise (arc welders, etc.). Otherwise, isolate the input power to the PowerStation from the equipment generating electrical noise.

The XP PowerStation's electrical specifications appear in Table A-4.

Table A-4: Electrical Specifications Chart

Category	XPR00/XPx06	XPx08 XPx10 XPx15
Input voltage	24 VDC @ .7A max Surge: 1.5A max (Range: min 10 VDC, 28 VDC max)	24 VDC @ 2A max (Range: min 18 VDC, 28 VDC max)
Heat Dissipation	10 Watts	20 Watts
Fuse	Littelfuse Nano SMF Slow Blow Type fuse. The part number is R454 002.	Littelfuse Nano SMF Very Fast-Acting Type fuse. The part number is R451 004.

Caution: Do not apply AC power to the unit or damage may occur.

Testing Specifications

The XP PowerStation conforms to the testing specifications listed below. Table A-5, shows the European community immunity and emission standards for electronic equipment: EN61000-6-2 (2001) and EN55011 (A2:2002).

Table A-5: European Community Specifications

Test	Specification
ESD immunity	EN61000-4-2
RF immunity	EN61000-4-3
Electrical fast transient/burst	EN61000-4-4
Surge immunity	EN61000-4-5
RF common mode immunity	EN61000-4-6
Power frequency magnetic field immunity	EN61000-4-8
Voltage dip and interrupt immunity	EN61000-4-11
Conducted & radiated emissions	EN55011

Table A-6, shows the mechanical testing specifications.

Table A-6: Mechanical Testing Specifications

Test	Specification
Surge withstanding capacitance	EN61000-4-5
ESD requirements	EN61000-4-2
Electrical fast transient	EN61000-4-4
Operating vibration	0.5 grms/MIL-STD-810F 514.3
Mechanical shock	IEC-68-2-27/MIL-STD-810 516.3
Non-operational vibration	1.0 grms/MIL-STD-810F 514.3

Faceplate Chemical Resistance

The touchscreen of the XP PowerStation is resistant to the chemicals listed in Table A-7.

Table A-7: Chemical Resistance Chart

Touchscreen Chemical Resistance		
Acetone	Sulfuric Acid 10%	Motor oil
MEK	Hydrochloric Acid 10%	Gasoline
Toluene	Acetic Acid 10%	Machine oil
Methylene Chloride	Phosphoric Acid	Salad oil
Isopropyl Alcohol	Sodium Hydroxide 10%	Silicone
Xylene	Carbon Tetrachloride	Silicone grease G31
Hexane	Potassium Hydroxide	Kerosene
Butyl Cellosolve	Ammonia Water 10%	Gas oil
Cyclohexanone	Sodium Chloride 26%	Silicone oil
Trichloroethylene	Zinc Chloride 81%	Engine oil
Ethanol	Cottonseed Oil	Cleanser
Methanol	Glycerin	
Nitric Acid 10%	Grease	

Note: Sustained exposure to brake fluid or Gunk[®] brand degreaser can cause damage to monitor materials.

All XP PowerStation surfaces exposed outside your enclosure are resistive to the following chemicals:

• Commercial glass cleaners	• Silicone based lubricant
• Motor oil	• Alcohol (ethyl, methyl)
• Ammonia (10% dilute solution)	• Automatic transmission fluid
• Diesel fuel	• Hydraulic fluid
• Gasoline (leaded, unleaded)	

INDEX

A

AC Power Supply 4-11
 Guidelines 2-15
AC Power Supply Location 2-15

B

backshell
 closing 4-8
BIOS 3-14, A-2
bracket assembly 2-7
Bulb Life A-3

C

calibration 4-2
clamp
 mounting 2-7
Class 1, Div 2 rules 2-5
Class 1, Division 2 guidelines 2-5
Compact Flash
 Using 3-11
CompactFlash 3-9
 replacing 4-4
 writing 3-11
CompactFlash, restoring 3-11
connectors 3-2
cover
 closing 4-8

D

Dimensions A-2
Disk Boot Priority 3-16
Display Brightness A-3
Display Specifications A-2
Display Unit
 replacing 4-12
documentation
 library 1-3
 standards 1-3

E

Electrical Guidelines 2-2
electrostatic discharge 4-5
Enclosure Guidelines 2-4
Environmental Guidelines 2-2
ESD 4-5
Ethernet Port
 Pinouts 3-8

F

Fuse
 replacing 4-12
fuse
 maintenance 4-5
Fuse, Replacing the 4-9

G

getting started 1-6

I

I/O Ports A-2
Installing
 a Fuse 4-9, 4-10
Installing the PowerStation
 Cutout 2-6
 Preparation 2-6

K

Keyboard A-2

M

maintenance 4-1 to 4-8
Memory A-2
monitor
 calibrating 4-2
 mounting 2-7
 mounting diagram 2-11, 2-13
mounting bracket 2-7
mounting diagram 2-11, 2-13
Mounting Guidelines
 Enclosure 2-4
 Environmental 2-2
 Temperature 2-2
Mouse A-2

O

opening the PowerStation 4-6
Operating System A-2
Optional Components 4-11

P

Physical Specifications A-2
PowerStation Thermal
 Guidelines 2-2
PowerStation Utilities
 reinstalling 3-11
Preparing for Installation 2-6

R

Radiated Emissions Guidelines 2-4
Replaceable Fuse 4-12
Resolution A-3
RS-485 Directional Control 3-7

S

screen
 cleaning 4-1
screw assembly 2-12, 2-14, 2-15
SDRAM, replacing 4-12
Serial Cable Diagrams
 RS-232 3-4, 3-6
 RS-422 3-4, 3-6
 RS-485 3-4, 3-6
Serial Ports 3-2
Specifications
 Display A-3
 Electrical A-5
 Environmental A-4
 Faceplate Resistance A-7
 Physical A-2
 Testing A-6
Storage A-2
support
 contacting 1-5
 services 1-4
symbols
 caution 1-4
 warning 1-4

T

torque 2-12, 2-14
 wiring 2-2
Touchscreen A-2
training 1-5

U

UL (Underwriters
Laboratories) 2-1
utilities 4-12

W

Weight A-2
Wiring Requirements 2-2